

CHAPTER

6



Power Factor Improvement

- 6.1 Power Factor
- 6.2 Power Triangle
- 6.3 Disadvantages of Low Power Factor
- 6.4 Causes of Low Power Factor
- 6.5 Power Factor Improvement
- 6.6 Power Factor Improvement Equipment
- 6.7 Calculations of Power Factor Correction
- 6.8 Importance of Power Factor Improvement
- 6.9 Most Economical Power Factor
- 6.10 Meeting the Increased kW Demand on Power Stations

Introduction

The electrical energy is almost exclusively generated, transmitted and distributed in the form of alternating current. Therefore, the question of power factor immediately comes into picture. Most of the loads (*e.g.* induction motors, arc lamps) are inductive in nature and hence have low lagging power factor. The low power factor is highly undesirable as it causes an increase in current, resulting in additional losses of active power in all the elements of power system from power station generator down to the utilisation devices. In order to ensure most favourable conditions for a supply system from engineering and economical standpoint, it is important to have power factor as close to unity as possible. In this chapter, we shall discuss the various methods of power factor improvement.

6.1 Power Factor

*The cosine of angle between voltage and current in an a.c. circuit is known as **power factor**.*

In an a.c. circuit, there is generally a phase difference ϕ between voltage and current. The term $\cos \phi$ is called the power factor of the circuit. If the circuit is inductive, the current lags behind the voltage and the power factor is referred

to as lagging. However, in a capacitive circuit, current leads the voltage and power factor is said to be leading.

Consider an inductive circuit taking a lagging current I from supply voltage V ; the angle of lag being ϕ . The phasor diagram of the circuit is shown in Fig. 6.1. The circuit current I can be resolved into two perpendicular components, namely ;

- (a) $I \cos \phi$ in phase with V
- (b) $I \sin \phi$ 90° out of phase with V

The component $I \cos \phi$ is known as active or wattful component, whereas component $I \sin \phi$ is called the reactive or wattless component. The reactive component is a measure of the power factor. If the reactive component is small, the phase angle ϕ is small and hence power factor $\cos \phi$ will be high. Therefore, a circuit having small reactive current (*i.e.*, $I \sin \phi$) will have high power factor and *vice-versa*. It may be noted that value of power factor can never be more than unity.

- (i) It is a usual practice to attach the word ‘lagging’ or ‘leading’ with the numerical value of power factor to signify whether the current lags or leads the voltage. Thus if the circuit has a p.f. of 0.5 and the current lags the voltage, we generally write p.f. as 0.5 lagging.
- (ii) Sometimes power factor is expressed as a percentage. Thus 0.8 lagging power factor may be expressed as 80% lagging.

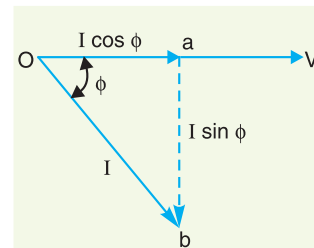

Fig. 6.1

6.2 Power Triangle

The analysis of power factor can also be made in terms of power drawn by the a.c. circuit. If each side of the current triangle oab of Fig. 6.1 is multiplied by voltage V , then we get the power triangle OAB shown in Fig. 6.2 where

- $OA = VI \cos \phi$ and represents the **active power** in watts or kW
- $AB = VI \sin \phi$ and represents the **reactive power** in VAR or kVAR
- $OB = VI$ and represents the **apparent power** in VA or kVA

The following points may be noted from the power triangle :

- (i) The apparent power in an a.c. circuit has two components *viz.*, active and reactive power at right angles to each other.

$$OB^2 = OA^2 + AB^2$$

$$\text{or } (\text{apparent power})^2 = (\text{active power})^2 + (\text{reactive power})^2$$

$$\text{or } (\text{kVA})^2 = (\text{kW})^2 + (\text{kVAR})^2$$

- (ii) Power factor, $\cos \phi = \frac{OA}{OB} = \frac{\text{active power}}{\text{apparent power}} = \frac{\text{kW}}{\text{kVA}}$

Thus the power factor of a circuit may also be defined as the ratio of active power to the apparent power. This is a perfectly general definition and can be applied to all cases, whatever be the waveform.

- (iii) The lagging* reactive power is responsible for the low power factor. It is clear from the power triangle that smaller the reactive power component, the higher is the power factor of the circuit.

$$\text{kVAR} = \text{kVA} \sin \phi = \frac{\text{kW}}{\cos \phi} \sin \phi$$

$$\therefore \text{kVAR} = \text{kW} \tan \phi$$

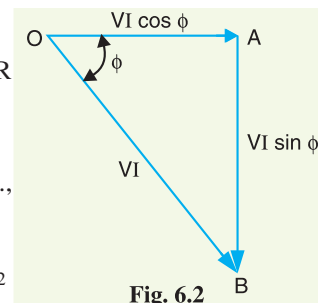

Fig. 6.2

* If the current lags behind the voltage, the reactive power drawn is known as lagging reactive power. However, if the circuit current leads the voltage, the reactive power is known as leading reactive power.

- (iv) For leading currents, the power triangle becomes reversed. This fact provides a key to the power factor improvement. If a device taking leading reactive power (*e.g.* capacitor) is connected in parallel with the load, then the lagging reactive power of the load will be partly neutralised, thus improving the power factor of the load.
- (v) The power factor of a circuit can be defined in one of the following three ways :
- (a) Power factor = $\cos \phi$ = cosine of angle between V and I
- (b) Power factor = $\frac{R}{Z} = \frac{\text{Resistance}}{\text{Impedance}}$
- (c) Power factor = $\frac{VI \cos \phi}{VI} = \frac{\text{Active power}}{\text{Apparent Power}}$
- (vi) The reactive power is neither consumed in the circuit nor it does any useful work. It merely flows back and forth in both directions in the circuit. A wattmeter does not measure reactive power.

Illustration. Let us illustrate the power relations in an a.c. circuit with an example. Suppose a circuit draws a current of 10 A at a voltage of 200 V and its p.f. is 0.8 lagging. Then,

$$\text{Apparent power} = VI = 200 \times 10 = 2000 \text{ VA}$$

$$\text{Active power} = VI \cos \phi = 200 \times 10 \times 0.8 = 1600 \text{ W}$$

$$\text{Reactive power} = VI \sin \phi = 200 \times 10 \times 0.6 = 1200 \text{ VAR}$$

The circuit receives an apparent power of 2000 VA and is able to convert only 1600 watts into active power. The reactive power is 1200 VAR and does no useful work. It merely flows into and out of the circuit periodically. In fact, reactive power is a liability on the source because the source has to supply the additional current (*i.e.*, $I \sin \phi$).

6.3 Disadvantages of Low Power Factor

The power factor plays an importance role in a.c. circuits since power consumed depends upon this factor.

$$P = V_L I_L \cos \phi \quad (\text{For single phase supply})$$

$$\therefore I_L = \frac{P}{V_L \cos \phi} \quad \dots(i)$$

$$P = \sqrt{3} V_L I_L \cos \phi \quad (\text{For 3 phase supply})$$

$$\therefore I_L = \frac{P}{\sqrt{3} V_L \cos \phi} \quad \dots(ii)$$

It is clear from above that for fixed power and voltage, the load current is inversely proportional to the power factor. Lower the power factor, higher is the load current and *vice-versa*. A power factor less than unity results in the following disadvantages :

- (i) **Large kVA rating of equipment.** The electrical machinery (*e.g.*, alternators, transformers, switchgear) is always rated in *kVA.

$$\text{Now,} \quad \text{kVA} = \frac{\text{kW}}{\cos \phi}$$

It is clear that kVA rating of the equipment is inversely proportional to power factor. The smaller the power factor, the larger is the kVA rating. Therefore, at low power factor, the kVA rating of the equipment has to be made more, making the equipment larger and expensive.

- (ii) **Greater conductor size.** To transmit or distribute a fixed amount of power at constant voltage, the conductor will have to carry more current at low power factor. This necessitates

* The electrical machinery is rated in kVA because the power factor of the load is not known when the machinery is manufactured in the factory.

large conductor size. For example, take the case of a single phase a.c. motor having an input of 10 kW on full load, the terminal voltage being 250 V. At unity p.f., the input full load current would be $10,000/250 = 40$ A. At 0.8 p.f.; the kVA input would be $10/0.8 = 12.5$ and the current input $12,500/250 = 50$ A. If the motor is worked at a low power factor of 0.8, the cross-sectional area of the supply cables and motor conductors would have to be based upon a current of 50 A instead of 40 A which would be required at unity power factor.

- (iii) **Large copper losses.** The large current at low power factor causes more I^2R losses in all the elements of the supply system. This results in poor efficiency.
- (iv) **Poor voltage regulation.** The large current at low lagging power factor causes greater voltage drops in alternators, transformers, transmission lines and distributors. This results in the decreased voltage available at the supply end, thus impairing the performance of utilisation devices. In order to keep the receiving end voltage within permissible limits, extra equipment (*i.e.*, voltage regulators) is required.
- (v) **Reduced handling capacity of system.** The lagging power factor reduces the handling capacity of all the elements of the system. It is because the reactive component of current prevents the full utilisation of installed capacity.

The above discussion leads to the conclusion that low power factor is an objectionable feature in the supply system

6.4 Causes of Low Power Factor

Low power factor is undesirable from economic point of view. Normally, the power factor of the whole load on the supply system is lower than 0.8. The following are the causes of low power factor:

- (i) Most of the a.c. motors are of induction type (1 ϕ and 3 ϕ induction motors) which have low lagging power factor. These motors work at a power factor which is extremely small on light load (0.2 to 0.3) and rises to 0.8 or 0.9 at full load.
- (ii) Arc lamps, electric discharge lamps and industrial heating furnaces operate at low lagging power factor.
- (iii) The load on the power system is varying ; being high during morning and evening and low at other times. During low load period, supply voltage is increased which increases the magnetisation current. This results in the decreased power factor.

6.5 Power Factor Improvement

The low power factor is mainly due to the fact that most of the power loads are inductive and, therefore, take lagging currents. In order to improve the power factor, some device taking leading power should be connected in parallel with the load. One of such devices can be a capacitor. The capacitor draws a leading current and partly or completely neutralises the lagging reactive component of load current. This raises the power factor of the load.

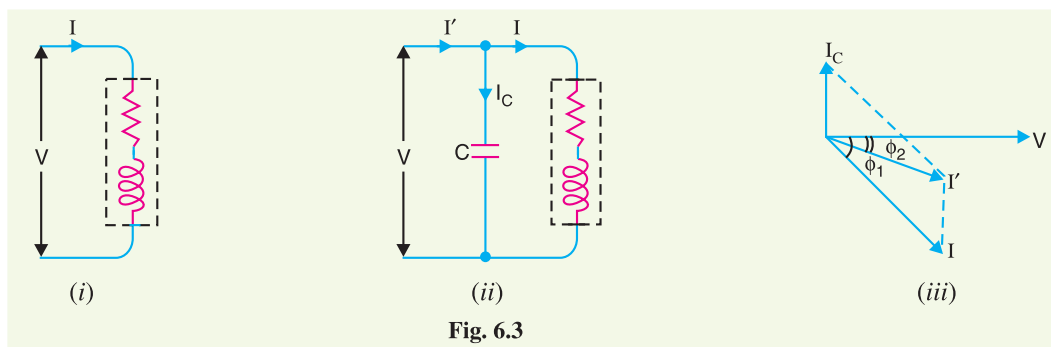

Fig. 6.3

Illustration. To illustrate the power factor improvement by a capacitor, consider a single *phase load taking lagging current I at a power factor $\cos \phi_1$ as shown in Fig. 6.3.

The capacitor C is connected in parallel with the load. The capacitor draws current I_C which leads the supply voltage by 90° . The resulting line current I' is the phasor sum of I and I_C and its angle of lag is ϕ_2 as shown in the phasor diagram of Fig. 6.3. (iii). It is clear that ϕ_2 is less than ϕ_1 , so that $\cos \phi_2$ is greater than $\cos \phi_1$. Hence, the power factor of the load is improved. The following points are worth noting :

- (i) The circuit current I' after p.f. correction is less than the original circuit current I .
 (ii) The active or wattful component remains the same before and after p.f. correction because only the lagging reactive component is reduced by the capacitor.

$$\therefore I \cos \phi_1 = I' \cos \phi_2$$

- (iii) The lagging reactive component is reduced after p.f. improvement and is equal to the difference between lagging reactive component of load ($I \sin \phi_1$) and capacitor current (I_C) i.e.,

$$I' \sin \phi_2 = I \sin \phi_1 - I_C$$

- (iv) As $I \cos \phi_1 = I' \cos \phi_2$
 $\therefore VI \cos \phi_1 = VI' \cos \phi_2$ [Multiplying by V]

Therefore, active power (kW) remains unchanged due to power factor improvement.

- (v) $I' \sin \phi_2 = I \sin \phi_1 - I_C$
 $\therefore VI' \sin \phi_2 = VI \sin \phi_1 - VI_C$ [Multiplying by V]

i.e., Net kVAR after p.f. correction = Lagging kVAR before p.f. correction – leading kVAR of equipment

6.6 Power Factor Improvement Equipment

Normally, the power factor of the whole load on a large generating station is in the region of 0.8 to 0.9. However, sometimes it is lower and in such cases it is generally desirable to take special steps to improve the power factor. This can be achieved by the following equipment :

1. Static capacitors.
2. Synchronous condenser.
3. Phase advancers.

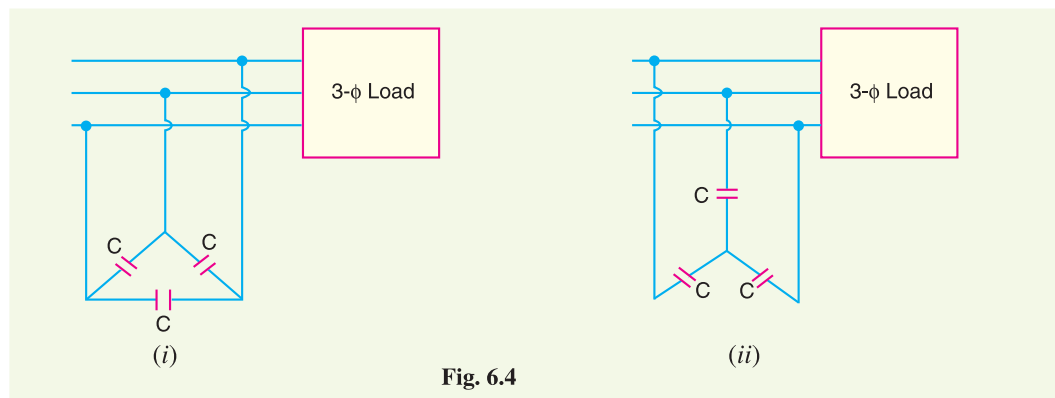

1. Static capacitor. The power factor can be improved by connecting capacitors in parallel with the equipment operating at lagging power factor. The capacitor (generally known as static**

* The treatment can be used for 3-phase balanced loads e.g., 3- ϕ induction motor. In a balanced 3- ϕ load, analysis of one phase leads to the desired results.

** To distinguish from the so called *synchronous condenser* which is a synchronous motor running at no load and taking leading current.

capacitor) draws a leading current and partly or completely neutralises the lagging reactive component of load current. This raises the power factor of the load. For three-phase loads, the capacitors can be connected in delta or star as shown in Fig. 6.4. Static capacitors are invariably used for power factor improvement in factories.

Advantages

- (i) They have low losses.
- (ii) They require little maintenance as there are no rotating parts.
- (iii) They can be easily installed as they are light and require no foundation.
- (iv) They can work under ordinary atmospheric conditions.

Disadvantages

- (i) They have short service life ranging from 8 to 10 years.
- (ii) They are easily damaged if the voltage exceeds the rated value.
- (iii) Once the capacitors are damaged, their repair is uneconomical.

2. Synchronous condenser. A synchronous motor takes a leading current when over-excited and, therefore, behaves as a capacitor. An over-excited synchronous motor running on no load is known as *synchronous condenser*. When such a machine is connected in parallel with the supply, it takes a leading current which partly neutralises the lagging reactive component of the load. Thus the power factor is improved.

Fig 6.5 shows the power factor improvement by synchronous condenser method. The 3 ϕ load takes current I_L at low lagging power factor $\cos \phi_L$. The synchronous condenser takes a current I_m which leads the voltage by an angle ϕ_m^* . The resultant current I is the phasor sum of I_m and I_L and lags behind the voltage by an angle ϕ . It is clear that ϕ is less than ϕ_L so that $\cos \phi$ is greater than $\cos \phi_L$. Thus the power factor is increased from $\cos \phi_L$ to $\cos \phi$. Synchronous condensers are generally used at major bulk supply substations for power factor improvement.

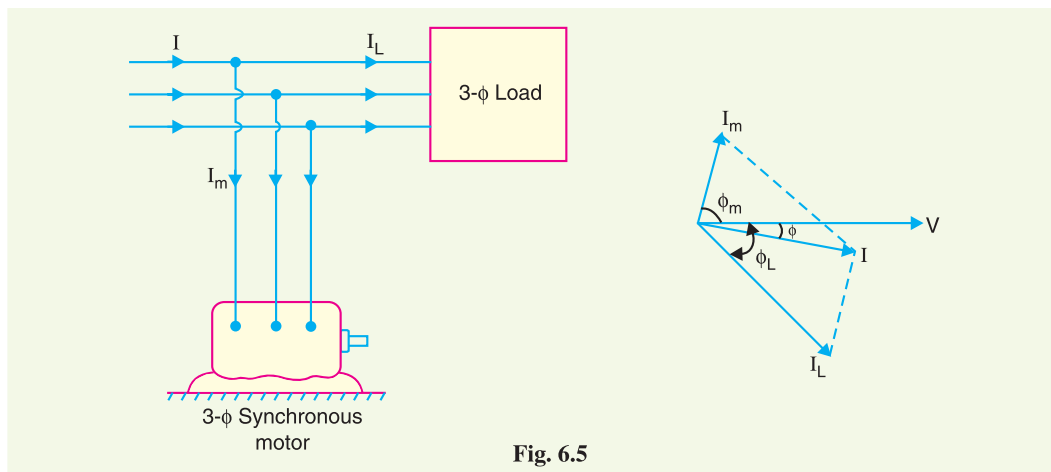

Fig. 6.5

Advantages

- (i) By varying the field excitation, the magnitude of current drawn by the motor can be changed by any amount. This helps in achieving stepless † control of power factor.

* If the motor is ideal *i.e.*, there are no losses, then $\phi_m = 90^\circ$. However, in actual practice, losses do occur in the motor even at no load. Therefore, the currents I_m leads the voltage by an angle less than 90° .

† The *p.f.* improvement with capacitors can only be done in steps by switching on the capacitors in various groupings. However, with synchronous motor, any amount of capacitive reactance can be provided by changing the field excitation.

- (ii) The motor windings have high thermal stability to short circuit currents.
- (iii) The faults can be removed easily.

Disadvantages

- (i) There are considerable losses in the motor.
- (ii) The maintenance cost is high.
- (iii) It produces noise.
- (iv) Except in sizes above 500 kVA, the cost is greater than that of static capacitors of the same rating.
- (v) As a synchronous motor has no self-starting torque, therefore, an auxiliary equipment has to be provided for this purpose.

Note. The reactive power taken by a synchronous motor depends upon two factors, the d.c. field excitation and the mechanical load delivered by the motor. Maximum leading power is taken by a synchronous motor with maximum excitation and zero load.

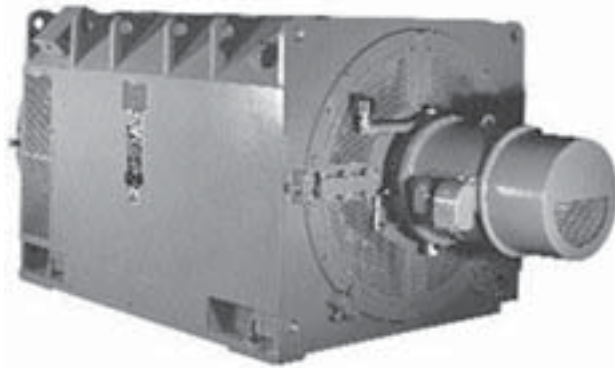

Synchronous Condenser

3. Phase advancers. Phase advancers are used to improve the power factor of induction motors. The low power factor of an induction motor is due to the fact that its stator winding draws exciting current which lags behind the supply voltage by 90° . If the exciting ampere turns can be provided from some other a.c. source, then the stator winding will be relieved of exciting current and the power factor of the motor can be improved. This job is accomplished by the phase advancer which is simply an a.c. exciter. The phase advancer is mounted on the same shaft as the main motor and is connected in the rotor circuit of the motor. It provides exciting ampere turns to the rotor circuit at slip frequency. By providing more ampere turns than required, the induction motor can be made to operate on leading power factor like an over-excited synchronous motor.

Phase advancers have two principal advantages. Firstly, as the exciting ampere turns are supplied at slip frequency, therefore, lagging kVAR drawn by the motor are considerably reduced. Secondly, phase advancer can be conveniently used where the use of synchronous motors is inadmissible. However, the major disadvantage of phase advancers is that they are not economical for motors below 200 H.P.



Static Capacitor

6.7 Calculations of Power Factor Correction

Consider an inductive load taking a lagging current I at a power factor $\cos \phi_1$. In order to improve the power factor of this circuit, the remedy is to connect such an equipment in parallel with the load which takes a leading reactive component and partly cancels the lagging reactive component of the load. Fig. 6.6 (i) shows a capacitor connected across the load. The capacitor takes a current I_C which leads the supply voltage V by 90° . The current I_C partly cancels the lagging reactive component of the load current as shown in the phasor diagram in Fig. 6.6 (ii). The resultant circuit current becomes I' and its angle of lag is ϕ_2 . It is clear that ϕ_2 is less than ϕ_1 so that new p.f. $\cos \phi_2$ is more than the previous p.f. $\cos \phi_1$.

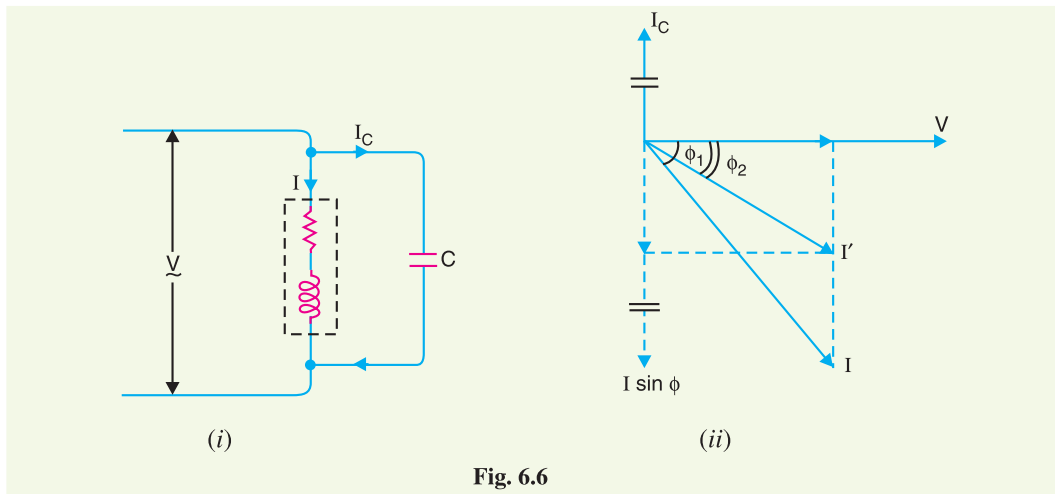

Fig. 6.6

From the phasor diagram, it is clear that after p.f. correction, the lagging reactive component of the load is reduced to $I' \sin \phi_2$.

$$\text{Obviously, } I' \sin \phi_2 = I \sin \phi_1 - I_C$$

$$\text{or } I_C = I \sin \phi_1 - I' \sin \phi_2$$

\therefore Capacitance of capacitor to improve p.f. from $\cos \phi_1$ to $\cos \phi_2$

$$= \frac{I_C}{\omega V} \quad \left(\because X_C = \frac{V}{I_C} = \frac{1}{\omega C} \right)$$

Power triangle. The power factor correction can also be illustrated from power triangle. Thus referring to Fig. 6.7, the power triangle OAB is for the power factor $\cos \phi_1$, whereas power triangle OAC is for the improved power factor $\cos \phi_2$. It may be seen that active power (OA) does not change with power factor improvement. However, the lagging kVAR of the load is reduced by the p.f. correction equipment, thus improving the p.f. to $\cos \phi_2$.

$$\begin{aligned} \text{Leading kVAR supplied by p.f. correction equipment} \\ &= BC = AB - AC \\ &= \text{kVAR}_1 - \text{kVAR}_2 \\ &= OA (\tan \phi_1 - \tan \phi_2) \\ &= \text{kW} (\tan \phi_1 - \tan \phi_2) \end{aligned}$$

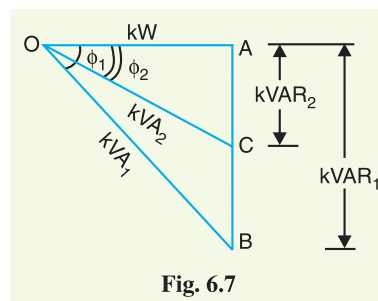

Fig. 6.7

Knowing the leading kVAR supplied by the p.f. correction equipment, the desired results can be obtained.

Example 6.1 An alternator is supplying a load of 300 kW at a p.f. of 0.6 lagging. If the power factor is raised to unity, how many more kilowatts can alternator supply for the same kVA loading ?

Solution :

$$\text{kVA} = \frac{\text{kW}}{\cos \phi} = \frac{300}{0.6} = 500 \text{ kVA}$$

$$\text{kW at 0.6 p.f.} = 300 \text{ kW}$$

$$\text{kW at 1 p.f.} = 500 \times 1 = 500 \text{ kW}$$

$$\begin{aligned} \therefore \text{Increased power supplied by the alternator} \\ = 500 - 300 = \mathbf{200 \text{ kW}} \end{aligned}$$

Note the importance of power factor improvement. When the p.f. of the alternator is unity, the 500 kVA are also 500 kW and the engine driving the alternator has to be capable of developing this power together with the losses in the alternator. But when the power factor of the load is 0.6, the power is only 300 kW. Therefore, the engine is developing only 300 kW, though the alternator is supplying its rated output of 500 kVA.

Example 6.2 A single phase motor connected to 400 V, 50 Hz supply takes 31.7A at a power factor of 0.7 lagging. Calculate the capacitance required in parallel with the motor to raise the power factor to 0.9 lagging.

Solution : The circuit and phasor diagrams are shown in Figs. 6.8 and 6.9 respectively. Here motor M is taking a current I_M of 31.7A. The current I_C taken by the capacitor must be such that when combined with I_M , the resultant current I lags the voltage by an angle ϕ where $\cos \phi = 0.9$.

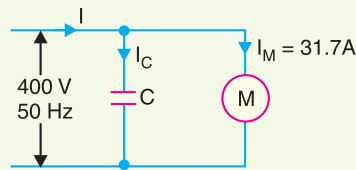

Fig. 6.8

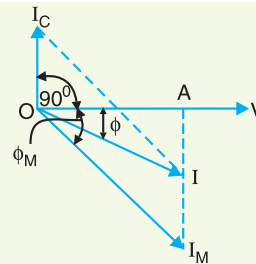

Fig. 6.9

Referring to the phasor diagram in Fig. 6.9,

$$\text{Active component of } I_M = I_M \cos \phi_M = 31.7 \times 0.7 = 22.19 \text{ A}$$

$$\text{Active component of } I = I \cos \phi = I \times 0.9$$

These components are represented by OA in Fig. 6.9.

$$\therefore I = \frac{22.19}{0.9} = 24.65 \text{ A}$$

$$\text{Reactive component of } I_M = I_M \sin \phi_M = 31.7 \times 0.714^* = 22.6 \text{ A}$$

$$\begin{aligned} \text{Reactive component of } I &= I \sin \phi = 24.65 \sqrt{1 - (0.9)^2} \\ &= 24.65 \times 0.436 = 10.75 \text{ A} \end{aligned}$$

It is clear from Fig. 6.9 that :

$$\begin{aligned} I_C &= \text{Reactive component of } I_M - \text{Reactive component of } I \\ &= 22.6 - 10.75 = 11.85 \text{ A} \end{aligned}$$

$$\text{But } I_C = \frac{V}{X_C} = V \times 2\pi f C$$

$$\text{or } 11.85 = 400 \times 2\pi \times 50 \times C$$

$$\therefore C = 94.3 \times 10^{-6} \text{ F} = \mathbf{94.3 \mu\text{F}}$$

* $\sin \phi_M = \sqrt{1 - \cos^2 \phi_M} = \sqrt{1 - (0.7)^2} = 0.714$

Note the effect of connecting a $94.3 \mu\text{F}$ capacitor in parallel with the motor. The current taken from the supply is reduced from 31.7 A to 24.65 A without altering the current or power taken by the motor. This enables an economy to be affected in the size of generating plant and in the cross-sectional area of the conductors.

Example 6.3 A single phase a.c. generator supplies the following loads :

- (i) Lighting load of 20 kW at unity power factor.
- (ii) Induction motor load of 100 kW at p.f. 0.707 lagging.
- (iii) Synchronous motor load of 50 kW at p.f. 0.9 leading.

Calculate the total kW and kVA delivered by the generator and the power factor at which it works.

Solution : Using the suffixes 1, 2 and 3 to indicate the different loads, we have,

$$\text{kVA}_1 = \frac{\text{kW}_1}{\cos \phi_1} = \frac{20}{1} = 20 \text{ kVA}$$

$$\text{kVA}_2 = \frac{\text{kW}_2}{\cos \phi_2} = \frac{100}{0.707} = 141.4 \text{ kVA}$$

$$\text{kVA}_3 = \frac{\text{kW}_3}{\cos \phi_3} = \frac{50}{0.9} = 55.6 \text{ kVA}$$

These loads are represented in Fig. 6.10. The three kVAs' are not in phase. In order to find the total kVA, we resolve each kVA into rectangular components – kW and kVAR as shown in Fig. 6.10. The total kW and kVAR may then be combined to obtain total kVA.

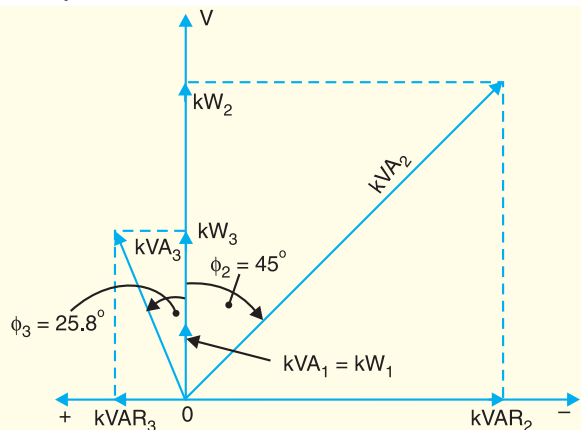

Fig. 6.10

$$\text{kVAR}_1 = \text{kVA}_1 \sin \phi_1 = 20 \times 0 = 0$$

$$\text{kVAR}_2 = \text{kVA}_2 \sin \phi_2 = -141.4 \times 0.707 = -100 \text{ kVAR}$$

$$\text{kVAR}_3 = \text{kVA}_3 \sin \phi_3 = +55.6 \times 0.436 = +24.3 \text{ kVAR}$$

Note that kVAR_2 and kVAR_3 are in opposite directions ; kVAR_2 being a lagging while kVAR_3 being a leading kVAR.

$$\text{Total kW} = 20 + 100 + 50 = \mathbf{170 \text{ kW}}$$

$$\text{Total kVAR} = 0 - 100 + 24.3 = -75.7 \text{ kVAR}$$

$$\text{Total kVA} = \sqrt{(\text{kW})^2 + (\text{kVAR})^2} = \sqrt{(170)^2 + (75.7)^2} = \mathbf{186 \text{ kVA}}$$

$$\text{Power factor} = \frac{\text{Total kW}}{\text{Total kVA}} = \frac{170}{186} = \mathbf{0.914 \text{ lagging}}$$

The power factor must be lagging since the resultant kVAR is lagging.

Example 6.4 A 3-phase, 5 kW induction motor has a p.f. of 0.75 lagging. A bank of capacitors is connected in delta across the supply terminals and p.f. raised to 0.9 lagging. Determine the kVAR rating of the capacitors connected in each phase.

Solution :

$$\begin{aligned} \text{Original p.f., } \cos \phi_1 &= 0.75 \text{ lag} && \text{Motor input, } P = 5 \text{ kW} \\ \text{Final p.f., } \cos \phi_2 &= 0.9 \text{ lag} && \text{Efficiency, } \eta = 100 \% \text{ (assumed)} \\ \phi_1 &= \cos^{-1}(0.75) = 41.41^\circ && \tan \phi_1 = \tan 41.41^\circ = 0.8819 \\ \phi_2 &= \cos^{-1}(0.9) = 25.84^\circ && \tan \phi_2 = \tan 25.84^\circ = 0.4843 \end{aligned}$$

$$\begin{aligned} \text{Leading kVAR taken by the condenser bank} \\ &= P (\tan \phi_1 - \tan \phi_2) \\ &= 5 (0.8819 - 0.4843) = 1.99 \text{ kVAR} \end{aligned}$$

$$\begin{aligned} \therefore \text{Rating of capacitors connected in each phase} \\ &= 1.99/3 = \mathbf{0.663 \text{ kVAR}} \end{aligned}$$

Example 6.5 A 3-phase, 50 Hz, 400 V motor develops 100 H.P. (74.6 kW), the power factor being 0.75 lagging and efficiency 93%. A bank of capacitors is connected in delta across the supply terminals and power factor raised to 0.95 lagging. Each of the capacitance units is built of 4 similar 100 V capacitors. Determine the capacitance of each capacitor.

Solution :

$$\begin{aligned} \text{Original p.f., } \cos \phi_1 &= 0.75 \text{ lag} && \text{Final p.f., } \cos \phi_2 = 0.95 \text{ lag} \\ \text{Motor input, } P &= \text{output}/\eta = 74.6/0.93 = 80 \text{ kW} \\ \phi_1 &= \cos^{-1}(0.75) = 41.41^\circ \\ \tan \phi_1 &= \tan 41.41^\circ = 0.8819 \\ \phi_2 &= \cos^{-1}(0.95) = 18.19^\circ \\ \tan \phi_2 &= \tan 18.19^\circ = 0.3288 \end{aligned}$$

$$\begin{aligned} \text{Leading kVAR taken by the condenser bank} \\ &= P (\tan \phi_1 - \tan \phi_2) \\ &= 80 (0.8819 - 0.3288) = 44.25 \text{ kVAR} \end{aligned}$$

$$\begin{aligned} \text{Leading kVAR taken by each of three sets} \\ &= 44.25/3 = 14.75 \text{ kVAR} \quad \dots (i) \end{aligned}$$

Fig. 6.11 shows the delta* connected condenser bank. Let C farad be the capacitance of 4 capacitors in each phase.

Phase current of capacitor is

$$\begin{aligned} I_{CP} &= V_{ph}/X_C = 2\pi f C V_{ph} \\ &= 2\pi \times 50 \times C \times 400 \\ &= 1,25,600 C \text{ amperes} \end{aligned}$$

$$\begin{aligned} \text{kVAR/phase} &= \frac{V_{ph} I_{CP}}{1000} \\ &= \frac{400 \times 1,25,600 C}{1000} \\ &= 50240 C \quad \dots (ii) \end{aligned}$$

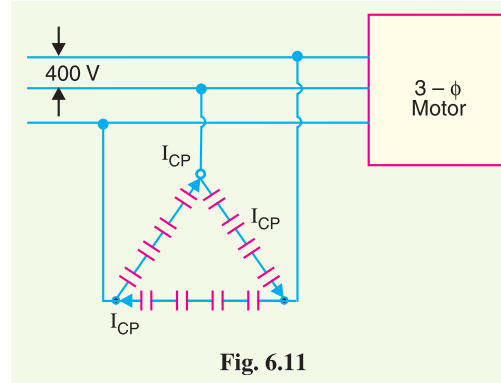

Fig. 6.11

* In practice, capacitors are always connected in delta since the capacitance of the capacitor required is one-third of that required for star connection.

Equating exps. (i) and (ii), we get,

$$50240 C = 14.75$$

$$\therefore C = 14.75/50,240 = 293.4 \times 10^{-6} \text{ F} = 293.4 \mu\text{F}$$

Since it is the combined capacitance of four equal capacitors joined in series,

$$\therefore \text{Capacitance of each capacitor} = 4 \times 293.4 = \mathbf{1173.6 \mu\text{F}}$$

Example 6.6. The load on an installation is 800 kW, 0.8 lagging p.f. which works for 3000 hours per annum. The tariff is Rs 100 per kVA plus 20 paise per kWh. If the power factor is improved to 0.9 lagging by means of loss-free capacitors costing Rs 60 per kVAR, calculate the annual saving effected. Allow 10% per annum for interest and depreciation on capacitors.

Solution.

$$\text{Load, } P = 800 \text{ kW}$$

$$\cos \phi_1 = 0.8 \quad ; \quad \tan \phi_1 = \tan (\cos^{-1} 0.8) = 0.75$$

$$\cos \phi_2 = 0.9 \quad ; \quad \tan \phi_2 = \tan (\cos^{-1} 0.9) = 0.4843$$

Leading kVAR taken by the capacitors

$$= P (\tan \phi_1 - \tan \phi_2) = 800 (0.75 - 0.4843) = 212.56$$

Annual cost before p.f. correction

$$\text{Max. kVA demand} = 800/0.8 = 1000$$

$$\text{kVA demand charges} = \text{Rs } 100 \times 1000 = \text{Rs } 1,00,000$$

$$\text{Units consumed/year} = 800 \times 3000 = 24,00,000 \text{ kWh}$$

$$\text{Energy charges/year} = \text{Rs } 0.2 \times 24,00,000 = \text{Rs } 4,80,000$$

$$\text{Total annual cost} = \text{Rs } (1,00,000 + 4,80,000) = \text{Rs } 5,80,000$$

Annual cost after p.f. correction

$$\text{Max. kVA demand} = 800/0.9 = 888.89$$

$$\text{kVA demand charges} = \text{Rs } 100 \times 888.89 = \text{Rs } 88,889$$

$$\text{Energy charges} = \text{Same as before i.e., Rs } 4,80,000$$

$$\text{Capital cost of capacitors} = \text{Rs } 60 \times 212.56 = \text{Rs } 12,750$$

$$\text{Annual interest and depreciation} = \text{Rs } 0.1 \times 12750 = \text{Rs } 1275$$

$$\text{Total annual cost} = \text{Rs } (88,889 + 4,80,000 + 1275) = \text{Rs } 5,70,164$$

$$\therefore \text{Annual saving} = \text{Rs } (5,80,000 - 5,70,164) = \mathbf{\text{Rs } 9836}$$

Example 6.7. A factory takes a load of 200 kW at 0.85 p.f. lagging for 2500 hours per annum. The tariff is Rs 150 per kVA plus 5 paise per kWh consumed. If the p.f. is improved to 0.9 lagging by means of capacitors costing Rs 420 per kVAR and having a power loss of 100 W per kVA, calculate the annual saving effected by their use. Allow 10% per annum for interest and depreciation.

Solution :

$$\text{Factory load, } P_1 = 200 \text{ kW}$$

$$\cos \phi_1 = 0.85 \quad ; \quad \tan \phi_1 = 0.62$$

$$\cos \phi_2 = 0.9 \quad ; \quad \tan \phi_2 = 0.4843$$

Suppose the leading kVAR taken by the capacitors is x .

$$\therefore \text{Capacitor loss} = \frac{100 \times x}{1000} = 0.1 x \text{ kW}$$

$$\text{Total power, } P_2 = (200 + 0.1x) \text{ kW}$$

Leading kVAR taken by the capacitors is

$$\begin{aligned} x &= P_1 \tan \phi_1 - P_2 \tan \phi_2 \\ &= 200 \times 0.62 - (200 + 0.1x) \times 0.4843 \end{aligned}$$

$$\begin{aligned} \text{or} \quad x &= 124 - 96.86 - 0.04843 x \\ \therefore x &= 27.14 / 1.04843 = 25.89 \text{ kVAR} \end{aligned}$$

Annual cost before p.f. improvement

$$\begin{aligned} \text{Max. kVA demand} &= 200 / 0.85 = 235.3 \\ \text{kVA demand charges} &= \text{Rs } 150 \times 235.3 = \text{Rs } 35,295 \\ \text{Units consumed/year} &= 200 \times 2500 = 5,00,000 \text{ kWh} \\ \text{Energy charges} &= \text{Rs } 0.05 \times 5,00,000 = \text{Rs } 25,000 \\ \text{Total annual cost} &= \text{Rs } (35,295 + 25,000) = \text{Rs } 60,295 \end{aligned}$$

Annual cost after p.f. improvement

$$\begin{aligned} \text{Max. kVA demand} &= 200 / 0.9 = 222.2 \\ \text{kVA demand charges} &= \text{Rs } 150 \times 222.2 = \text{Rs } 33,330 \\ \text{Energy charges} &= \text{same as before i.e., Rs } 25,000 \\ \text{Annual interest and depreciation} &= \text{Rs } 420 \times 25.89 \times 0.1 = \text{Rs } 1087 \\ \text{Annual energy loss in capacitors} &= 0.1 x \times 2500 = 0.1 \times 25.89 \times 2500 = 6472 \text{ kWh} \\ \text{Annual cost of losses occurring in capacitors} &= \text{Rs } 0.05 \times 6472 = \text{Rs } 323 \\ \therefore \text{Total annual cost} &= \text{Rs } (33,330 + 25,000 + 1087 + 323) = \text{Rs } 59,740 \\ \text{Annual saving} &= \text{Rs } (60,295 - 59,740) = \text{Rs } 555 \end{aligned}$$

Example 6.8. A factory operates at 0.8 p.f. lagging and has a monthly demand of 750 kVA. The monthly power rate is Rs 8.50 per kVA. To improve the power factor, 250 kVA capacitors are installed in which there is negligible power loss. The installed cost of equipment is Rs 20,000 and fixed charges are estimated at 10% per year. Calculate the annual saving effected by the use of capacitors.

Solution.

Monthly demand is 750 kVA.

$$\cos \phi = 0.8 ; \sin \phi = \sin (\cos^{-1} 0.8) = 0.6$$

$$\text{kW component of demand} = \text{kVA} \times \cos \phi = 750 \times 0.8 = 600$$

$$\text{kVAR component of demand} = \text{kVA} \times \sin \phi = 750 \times 0.6 = 450$$

Leading kVAR taken by the capacitors is 250 kVAR. Therefore, net kVAR after p.f. improvement is $450 - 250 = 200$.

$$\therefore \text{ kVA after p.f. improvement} = \sqrt{(600)^2 + (200)^2} = 632.45$$

$$\text{Reduction in kVA} = 750 - 632.45 = 117.5$$

$$\text{Monthly saving on kVA charges} = \text{Rs } 8.5 \times 117.5 = \text{Rs } 998.75$$

$$\text{Yearly saving on kVA charges} = \text{Rs } 998.75 \times 12 = \text{Rs } 11,985$$

$$\text{Fixed charges/year} = \text{Rs } 0.1 \times 20,000 = \text{Rs } 2000$$

$$\text{Net annual saving} = \text{Rs } (11,985 - 2000) = \text{Rs } 9,985$$

Example 6.9. A synchronous motor improves the power factor of a load of 200 kW from 0.8 lagging to 0.9 lagging. Simultaneously the motor carries a load of 80 kW. Find (i) the leading kVAR taken by the motor (ii) kVA rating of the motor and (iii) power factor at which the motor operates.

Solution.

$$\text{Load, } P_1 = 200 \text{ kW ; Motor load, } P_2 = 80 \text{ kW}$$

$$\text{p.f. of load, } \cos \phi_1 = 0.8 \text{ lag}$$

$$\text{p.f. of combined load, } \cos \phi_2 = 0.9 \text{ lag}$$

Combined load, $P = P_1 + P_2 = 200 + 80 = 280 \text{ kW}$

In Fig. 6.12, ΔOAB is the power triangle for load, ΔODC for combined load and ΔBEC for the motor.

- (i) Leading kVAR taken by the motor
 $= CE = DE - DC = AB - DC$
 $[\because AB = DE]$
 $= P_1 \tan \phi_1 - P^* \tan \phi_2$
 $= 200 \tan (\cos^{-1} 0.8) - 280 \tan (\cos^{-1} 0.9)$
 $= 200 \times 0.75 - 280 \times 0.4843$
 $= \mathbf{14.4 \text{ kVAR}}$

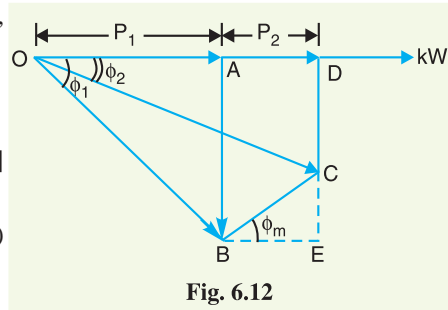

Fig. 6.12

- (ii) kVA rating of the motor $= BC = \sqrt{(BE)^2 + (EC)^2} = \sqrt{(80)^2 + (14.4)^2} = \mathbf{81.28 \text{ kVA}}$

- (iii) p.f. of motor, $\cos \phi_m = \frac{\text{Motor kW}}{\text{Motor kVA}} = \frac{80}{81.28} = \mathbf{0.984 \text{ leading}}$

Example 6.10. A factory load consists of the following :

- an induction motor of 50 H.P. (37.3 kW) with 0.8 p.f. and efficiency 0.85.
- a synchronous motor of 25 H.P. (18.65 kW) with 0.9 p.f. leading and efficiency 0.9.
- lighting load of 10 kW at unity p.f.

Find the annual electrical charges if the tariff is Rs 60 per kVA of maximum demand per annum plus 5 paise per kWh ; assuming the load to be steady for 2000 hours in a year.

Solution.

$$\text{Input power to induction motor} = 37.3/0.85 = 43.88 \text{ kW}$$

$$\text{Lagging kVAR taken by induction motor} = 43.88 \tan (\cos^{-1} 0.8) = 32.91$$

$$\text{Input power to synchronous motor}$$

$$= 18.65/0.9 = 20.72 \text{ kW}$$

$$\text{Leading kVAR taken by synchronous motor}$$

$$= 20.72 \tan (\cos^{-1} 0.9) = 10$$

Since lighting load works at unity p.f., its lagging kVAR = 0.

$$\text{Net lagging kVAR} = 32.91 - 10 = 22.91$$

$$\text{Total active power} = 43.88 + 20.72 + 10 = 74.6 \text{ kW}$$

$$\text{Total kVA} = \sqrt{(74.6)^2 + (22.91)^2} = 78$$

$$\text{Annual kVA demand charges} = \text{Rs } 60 \times 78 = \text{Rs } 4,680$$

$$\text{Energy consumed/year} = 74.6 \times 2000 = 1,49,200 \text{ kWh}$$

$$\text{Annual Energy charges} = \text{Rs } 0.05 \times 1,49,200 = \text{Rs } 7,460$$

$$\text{Total annual bill} = \text{kVA demand charges} + \text{Energy charges}$$

$$= \text{Rs } (4680 + 7460) = \mathbf{\text{Rs } 12,140}$$

Example 6.11. A supply system feeds the following loads (i) a lighting load of 500 kW (ii) a load of 400 kW at a p.f. of 0.707 lagging (iii) a load of 800 kW at a p.f. of 0.8 leading (iv) a load of 500 kW at a p.f. 0.6 lagging (v) a synchronous motor driving a 540 kW d.c. generator and having an overall efficiency of 90%. Calculate the power factor of synchronous motor so that the station power factor may become unity.

* In right angled triangle OAB , $AB = P_1 \tan \phi_1$

In right angled triangle ODC , $DC = OD \tan \phi_2 = (P_1 + P_2) \tan \phi_2 = P \tan \phi_2$

Solution. The lighting load works at unity p.f. and, therefore, its lagging kVAR is zero. The lagging kVAR are taken by the loads (ii) and (iv), whereas loads (iii) and (v) take the leading kVAR. For station power factor to be unity, the total lagging kVAR must be neutralised by the total leading kVAR. We know that $kVAR = kW \tan \phi$.

$$\begin{aligned} \therefore \text{Total lagging kVAR taken by loads (ii) and (iv)} & \\ &= 400 \tan (\cos^{-1} 0.707) + 500 \tan (\cos^{-1} 0.6) \\ &= 400 \times 1 + 500 \times 1.33 = 1065 \end{aligned}$$

$$\begin{aligned} \text{Leading kVAR taken by the load (iii)} & \\ &= 800 \tan (\cos^{-1} 0.8) = 800 \times 0.75 = 600 \end{aligned}$$

$$\begin{aligned} \therefore \text{Leading kVAR to be taken by synchronous motor} & \\ &= 1065 - 600 = 465 \text{ kVAR} \end{aligned}$$

$$\text{Motor input} = \text{output/efficiency} = 540/0.9 = 600 \text{ kW}$$

If ϕ is the phase angle of synchronous motor, then,

$$\tan \phi = kVAR/kW = 465/600 = 0.775$$

$$\therefore \phi = \tan^{-1} 0.775 = 37.77^\circ$$

$$\therefore \text{p.f. of synchronous motor} = \cos \phi = \cos 37.77^\circ = \mathbf{0.79 \text{ leading}}$$

Therefore, in order that the station power factor may become unity, the synchronous motor should be operated at a p.f. of 0.79 leading.

Example 6.12. An industrial load consists of (i) a synchronous motor of 100 metric h.p. (ii) induction motors aggregating 200 metric h.p., 0.707 power factor lagging and 82% efficiency and (iii) lighting load aggregating 30 kW.

The tariff is Rs 100 per annum per kVA maximum demand plus 6 paise per kWh. Find the annual saving in cost if the synchronous motor operates at 0.8 p.f. leading, 93% efficiency instead of 0.8 p.f. lagging at 93% efficiency.

Solution. The annual power bill will be calculated under two conditions viz., (a) when synchronous motor runs with lagging p.f. and (b) when synchronous motor runs with a leading p.f.

(a) **When synchronous motor runs at p.f. 0.8 lagging.** We shall find the combined kW and then calculate total kVA maximum demand using the relation :

$$kVA = \sqrt{(kW)^2 + (kVAR)^2}$$

$$\text{Input to synchronous motor} = \frac{100 \times 735.5}{0.93 \times 1000} = 79 \text{ kW}$$

$$\begin{aligned} \text{*Lagging kVAR taken by the synchronous motor} & \\ &= 79 \tan (\cos^{-1} 0.8) = 79 \times 0.75 = 59.25 \text{ kVAR} \end{aligned}$$

$$\text{Input to induction motors} = \frac{200 \times 735.5}{0.82 \times 1000} = 179.4 \text{ kW}$$

$$\begin{aligned} \text{Lagging kVAR taken by induction motors} & \\ &= 179.4 \tan (\cos^{-1} 0.707) = 179.4 \times 1 = 179.4 \text{ kVAR} \end{aligned}$$

Since lighting load works at unity p.f., its lagging kVAR is zero.

$$\therefore \text{Total lagging kVAR} = 59.25 + 179.4 = 238.65 \text{ kVAR}$$

$$\text{Total active power} = 79 + 179.4 + 30 = 288.4 \text{ kW}$$

$$\text{Total kVA} = \sqrt{(238.65)^2 + (288.4)^2} = 374.4 \text{ kVA}$$

$$\text{Annual kVA demand charges} = \text{Rs } 100 \times 374.4 = \text{Rs } 37,440$$

* Since the synchronous motor in this case runs at lagging p.f., it takes lagging kVAR.

$$\begin{aligned}\text{Energy consumed/year} &= 288.4 \times 8760 = 25,26384 \text{ kWh} \\ \text{Annual energy charges} &= \text{Rs } 0.06 \times 25,26,384 = \text{Rs } 1,51,583 \\ \text{Total annual bill} &= \text{Rs } (37,440 + 1,51,583) = \text{Rs } 1,89,023\end{aligned}$$

(b) When synchronous motor runs at p.f. 0.8 leading. As the synchronous motor runs at leading p.f. of 0.8 (instead of 0.8 p.f. lagging), therefore, it takes now 59.25 leading kVAR. The lagging kVAR taken by induction motors are the same as before *i.e.*, 179.4.

$$\begin{aligned}\therefore \quad \text{Net lagging kVAR} &= 179.4 - 59.25 = 120.15 \\ \text{Total active power} &= \text{Same as before } i.e., 288.4 \text{ kW} \\ \therefore \quad \text{Total kVA} &= \sqrt{(120.15)^2 + (288.4)^2} = 312.4 \\ \text{Annual kVA demand charges} &= \text{Rs } 100 \times 312.4 = \text{Rs } 31,240 \\ \text{Annual energy charges} &= \text{Same as before } i.e., \text{Rs } 1,51,583 \\ \text{Total annual bill} &= \text{Rs } (31,240 + 1,51,583) = \text{Rs } 1,82,823 \\ \therefore \quad \text{Annual saving} &= \text{Rs } (1,89,023 - 1,82,823) = \text{Rs } 6200\end{aligned}$$

TUTORIAL PROBLEMS

- What should be the kVA rating of a capacitor which would raise the power factor of load of 100 kW from 0.5 lagging to 0.9 lagging ? **[125 kVA]**
- A 3-phase, 50 Hz, 3300 V star connected induction motor develops 250 H.P. (186.5 kW), the power factor being 0.707 lagging and the efficiency 0.86. Three capacitors in delta are connected across the supply terminals and power factor raised to 0.9 lagging. Calculate :
 - the kVAR rating of the capacitor bank.
 - the capacitance of each unit. **[(i) 111.8 kVAR (ii) 10.9 μ F]**
- A 3-phase, 50 Hz, 3000 V motor develops 600 H.P. (447.6 kW), the power factor being 0.75 lagging and the efficiency 0.93. A bank of capacitors is connected in delta across the supply terminals and power factor raised to 0.95 lagging. Each of the capacitance units is built of five similar 600-V capacitors. Determine the capacitance of each capacitor. **[156 μ F]**
- A factory takes a load of 800 kW at 0.8 p.f. (lagging) for 3000 hours per annum and buys energy on tariff of Rs 100 per kVA plus 10 paise per kWh. If the power factor is improved to 0.9 lagging by means of capacitors costing Rs 60 per kVAR and having a power loss of 100 W per kVA, calculate the annual saving effected by their use. Allow 10% per annum for interest and depreciation on the capacitors. **[Rs 3972]**
- A station supplies 250 kVA at a lagging power factor of 0.8. A synchronous motor is connected in parallel with the load. If the combined load is 250 kW with a lagging p.f. of 0.9, determine :
 - the leading kVAR taken by the motor.
 - kVA rating of the motor.
 - p.f. at which the motor operates. **[(i) 28.9 kVAR (ii) 57.75 kVA (iii) 0.866 lead]**
- A generating station supplies power to the following :
 - a lighting load of 100 kW;
 - an induction motor 800 h.p. (596.8 kW) p.f. 0.8 lagging, efficiency 92%;
 - a rotary converter giving 150 A at 400 V at an efficiency of 0.95.
 What must be the power factor of the rotary converter in order that power factor of the supply station may become unity ? **[0.128 leading]**
- A 3-phase, 400 V synchronous motor having a power consumption of 50 kW is connected in parallel with an induction motor which takes 200 kW at a power factor of 0.8 lagging.
 - Calculate the current drawn from the mains when the power factor of the synchronous motor is unity.

- (ii) At what power factor should the synchronous motor operate so that the current drawn from the mains is minimum. ? [(i) 421 A (ii) 0.316 leading]
8. A factory load consists of the following :
- (i) an induction motor of 150 h.p. (111.9 kW) with 0.7 p.f. lagging and 80% efficiency ;
 - (ii) a synchronous motor of 100 h.p. (74.6 kW) with 0.85 p.f. leading at 90% efficiency ;
 - (iii) a lighting load of 50 kW.
- Find the annual electric charges if the tariff is Rs 100 per annum per kVA maximum demand plus 7 paise per kWh ; assuming the load to be steady throughout the year. [Rs 1,96,070]
9. A 3-phase synchronous motor having a mechanical load (including losses) of 122 kW is connected in parallel with a load of 510 kW at 0.8 p.f. lagging. The excitation of the motor is adjusted so that the kVA input to the motor becomes 140 kVA. Determine the new power factor of the whole system. [0.8956 lagging]
10. A 3-phase synchronous motor is connected in parallel with a load of 700 kW at 0.7 power factor lagging and its excitation is adjusted till it raises the total p.f. to 0.9 lagging. Mechanical load on the motor including losses is 150 kW. Find the power factor of the synchronous motor. [0.444 leading]

6.8 Importance of Power Factor Improvement

The improvement of power factor is very important for both consumers and generating stations as discussed below :

- (i) **For consumers.** A consumer* has to pay electricity charges for his maximum demand in kVA plus the units consumed. If the consumer improves the power factor, then there is a reduction† in his maximum kVA demand and consequently there will be annual saving due to maximum demand charges. Although power factor improvement involves extra annual expenditure on account of p.f. correction equipment, yet improvement of p.f. to a *proper value* results in the net annual saving for the consumer.
- (ii) **For generating stations.** A generating station is as much concerned with power factor improvement as the consumer. The generators in a power station are rated in kVA but the useful output depends upon kW output. As station output is $\text{kW} = \text{kVA} \times \cos \phi$, therefore, number of units supplied by it depends upon the power factor. The greater the power factor of the generating station, the higher is the kWh it delivers to the system. This leads to the conclusion that improved power factor increases the earning capacity of the power station.

6.9 Most Economical Power Factor

If a consumer improves the power factor, there is reduction in his maximum kVA demand and hence there will be annual saving over the maximum demand charges. However, when power factor is improved, it involves capital investment on the power factor correction equipment. The consumer will incur expenditure every year in the shape of annual interest and depreciation on the investment made over the p.f. correction equipment. Therefore, the *net annual saving* will be equal to the annual saving in maximum demand charges *minus* annual expenditure incurred on p.f. correction equipment.

The value to which the power factor should be improved so as to have maximum net annual saving is known as the **most economical power factor**.

Consider a consumer taking a peak load of P kW at a power factor of $\cos \phi_1$ and charged at a rate of Rs x per kVA of maximum demand per annum. Suppose the consumer improves the power factor

* This is not applicable to domestic consumers because the domestic load (e.g., lighting load) has a p.f. very close to unity. Here, consumer means industrial and other big consumers.

† $\text{Max. demand in kVA} = \frac{\text{Peak kW}}{\cos \phi}$

If $\cos \phi$ is more, maximum kVA demand will be less and *vice-versa*.

to $\cos \phi_2$ by installing p.f. correction equipment. Let expenditure incurred on the p.f. correction equipment be Rs y per kVAR per annum. The power triangle at the original p.f. $\cos \phi_1$ is OAB and for the improved p.f. $\cos \phi_2$, it is OAC [See Fig. 6.13].

kVA max. demand at $\cos \phi_1$, $kVA_1 = P/\cos \phi_1 = P \sec \phi_1$

kVA max. demand at $\cos \phi_2$, $kVA_2 = P/\cos \phi_2 = P \sec \phi_2$

Annual saving in maximum demand charges

$$= Rs \times (kVA_1 - kVA_2)$$

$$= Rs \times (P \sec \phi_1 - P \sec \phi_2)$$

$$= Rs \times P (\sec \phi_1 - \sec \phi_2) \quad \dots(i)$$

Reactive power at $\cos \phi_1$, $kVAR_1 = P \tan \phi_1$

Reactive power at $\cos \phi_2$, $kVAR_2 = P \tan \phi_2$

Leading kVAR taken by p.f. correction equipment

$$= P (\tan \phi_1 - \tan \phi_2)$$

Annual cost of p.f. correction equipment

$$= Rs \ P y (\tan \phi_1 - \tan \phi_2) \quad \dots(ii)$$

Net annual saving, $S = \text{exp. (i)} - \text{exp. (ii)}$

$$= xP (\sec \phi_1 - \sec \phi_2) - yP (\tan \phi_1 - \tan \phi_2)$$

In this expression, only ϕ_2 is variable while all other quantities are fixed. Therefore, the net annual saving will be maximum if differentiation of above expression w.r.t. ϕ_2 is zero i.e.

$$\frac{d}{d\phi_2} (S) = 0$$

$$\text{or } \frac{d}{d\phi_2} [xP (\sec \phi_1 - \sec \phi_2) - yP (\tan \phi_1 - \tan \phi_2)] = 0$$

$$\text{or } \frac{d}{d\phi_2} (xP \sec \phi_1) - \frac{d}{d\phi_2} (xP \sec \phi_2) - \frac{d}{d\phi_2} (yP \tan \phi_1) + yP \frac{d}{d\phi_2} (\tan \phi_2) = 0$$

$$\text{or } 0 - xP \sec \phi_2 \tan \phi_2 - 0 + yP \sec^2 \phi_2 = 0$$

$$\text{or } -x \tan \phi_2 + y \sec \phi_2 = 0$$

$$\text{or } \tan \phi_2 = \frac{y}{x} \sec \phi_2$$

$$\text{or } \sin \phi_2 = y/x$$

$$\therefore \text{ Most economical power factor, } \cos \phi_2 = \sqrt{1 - \sin^2 \phi_2} = \sqrt{1 - (y/x)^2}$$

It may be noted that the most economical power factor ($\cos \phi_2$) depends upon the relative costs of supply and p.f. correction equipment but is independent of the original p.f. $\cos \phi_1$.

Example 6.13 A factory which has a maximum demand of 175 kW at a power factor of 0.75 lagging is charged at Rs 72 per kVA per annum. If the phase advancing equipment costs Rs 120 per kVAR, find the most economical power factor at which the factory should operate. Interest and depreciation total 10% of the capital investment on the phase advancing equipment.

Solution :

Power factor of the factory, $\cos \phi_1 = 0.75$ lagging

Max. demand charges, $x = Rs 72$ per kVA per annum

Expenditure on phase advancing equipment, $y = Rs 120 \times 0.1 = Rs 12^*$ /kVAR/annum

* The total investment for producing 1 kVAR is Rs 120. The annual interest and depreciation is 10%. It means that an expenditure of $Rs 120 \times 10/100 = Rs 12$ is incurred on 1 kVAR per annum.

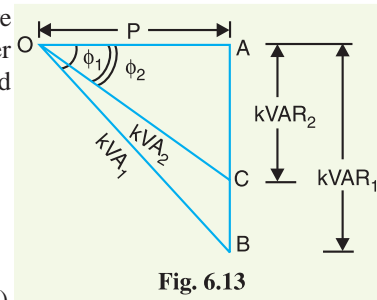

Fig. 6.13

∴ Most economical p.f. at which factory should operate is

$$\cos \phi_2 = \sqrt{1 - (y/x)^2} = \sqrt{1 - (12/72)^2} = \mathbf{0.986 \text{ lagging}}$$

Example 6.14 A consumer has an average demand of 400 kW at a p.f. of 0.8 lagging and annual load factor of 50%. The tariff is Rs 50 per kVA of maximum demand per annum plus 5 paise per kWh. If the power factor is improved to 0.95 lagging by installing phase advancing equipment, calculate :

- (i) the capacity of the phase advancing equipment
 (ii) the annual saving effected

The phase advancing equipment costs Rs 100 per kVAR and the annual interest and depreciation together amount to 10%.

Solution :

Max. kW demand, $P = 400/0.5 = 800$ kW

Original p.f., $\cos \phi_1 = 0.8$ lag ; Final p.f., $\cos \phi_2 = 0.95$ lag

$\phi_1 = \cos^{-1}(0.8) = 36.9^\circ$; $\tan \phi_1 = \tan 36.9^\circ = 0.75$

$\phi_2 = \cos^{-1}(0.95) = 18.2^\circ$; $\tan \phi_2 = \tan 18.2^\circ = 0.328$

(i) Leading kVAR taken by phase advancing equipment

$$= P (\tan \phi_1 - \tan \phi_2) = 800 (0.75 - 0.328) = 337 \text{ kVAR}$$

∴ Capacity of phase advancing equipment should be **337 kVAR**.

(ii) Max. demand charges, $x = \text{Rs } 50/\text{kVA}/\text{annum}$

Expenditure on phase advancing equipment

$$y = \text{Rs } 0.1 \times 100 = \text{Rs } 10/\text{kVAR}/\text{annum}$$

Max. kVA demand at 0.8 p.f. = $800/0.8 = 1000$ kVA

Max. kVA demand at 0.95 p.f. = $800/0.95 = 842$ kVA

Annual saving in maximum demand charges

$$= \text{Rs } 50 (1000 - 842) = \text{Rs } 7900$$

Annual expenditure on phase advancing equipment

$$= \text{Rs } (y \times \text{capacity of equipment})$$

$$= \text{Rs } 10 \times 337 = 3370$$

∴ Net annual saving = $\text{Rs } (7900 - 3370) = \mathbf{\text{Rs } 4530}$

Example 6.15 A factory has an average demand of 50 kW and an annual load factor of 0.5. The power factor is 0.75 lagging. The tariff is Rs 100 per kVA of maximum demand per annum plus 5 paise per kWh. If loss free capacitors costing Rs 600 per kVAR are to be utilised, find the value of power factor at which maximum saving will result. The interest and depreciation together amount to 10%. Also determine the annual saving effected by improving the p.f. to this value.

Solution :

Max. demand charge, $x = \text{Rs } 100/\text{kVA}/\text{annum}$

Expenditure on capacitors, $y = \text{Rs } 0.1 \times 600 = \text{Rs } 60/\text{kVAR}/\text{annum}$

Most economical p.f., $\cos \phi_2 = \sqrt{1 - (y/x)^2} = \sqrt{1 - (60/100)^2} = \mathbf{0.8 \text{ lag}}$

Max. kW demand = $50/0.5 = 100$ kW

The maximum kVA demand at 0.75 p.f. is = $100/0.75 = 133.34$ kVA, whereas it is = $100/0.8 = 125$ kVA at 0.8 p.f.

∴ Annual saving = $\text{Rs } 100 (133.34 - 125) = \mathbf{\text{Rs } 834}$

Example 6.16 A factory takes a steady load of 200 kW at a lagging power factor of 0.8. The tariff is Rs 100 per kVA of maximum demand per annum plus 5 paise per kWh. The phase advancing plant costs Rs 500 per kVAR and the annual interest and depreciation together amount to 10%. Find:

- (i) the value to which the power factor be improved so that annual expenditure is minimum
- (ii) the capacity of the phase advancing plant
- (iii) the new bill for energy, assuming that the factory works for 5000 hours per annum.

Solution :

Peak load of factory,	$P = 200 \text{ kW}$
Original power factor,	$\cos \phi_1 = 0.8 \text{ lagging}$
Max. demand charges,	$x = \text{Rs } 100/\text{kVA}/\text{annum}$
Charges on phase advancing plant,	$y = \text{Rs } 500 \times 0.1$ $= \text{Rs } 50/\text{kVAR}/\text{annum}$
(i) Most economical power factor, $\cos \phi_2$	$= \sqrt{1 - (y/x)^2} = \sqrt{1 - (50/100)^2} = \mathbf{0.866 \text{ lagging}}$
(ii) Capacity of phase advancing plant	$= P [\tan \phi_1 - \tan \phi_2]$ $= 200 [\tan (\cos^{-1} 0.8) - \tan (\cos^{-1} 0.866)]$ $= 200 [0.75 - 0.5774] = \mathbf{34.52 \text{ kVAR}}$
(iii) Units consumed/year	$= 200 \times 5000 = 10^6 \text{ kWh}$
Annual energy charges	$= \text{Rs } 0.05 \times 10^6 = \text{Rs } 50,000$
Annual cost of phase advancing plant	$= \text{Rs } y \times \text{Capacity of plant}$ $= \text{Rs } 50 \times 34.52 = \text{Rs } 1726$
Max. demand charge	$= \text{Rs } x \times P / \cos \phi_2 = \text{Rs } 100 \times 200 / 0.866 = \text{Rs } 23,094$
Annual bill for energy	$= \text{Rs } (50,000 + 1726 + 23,094) = \mathbf{\text{Rs } 74,820}$

Example 6.17 An industrial load takes 80,000 units in a year, the average power factor being 0.707 lagging. The recorded maximum demand is 500 kVA. The tariff is Rs 120 per kVA of maximum demand plus 2.5 paise per kWh. Calculate the annual cost of supply and find out the annual saving in cost by installing phase advancing plant costing Rs 50 per kVAR which raises the p.f. from 0.707 to 0.9 lagging. Allow 10% per year on the cost of phase advancing plant to cover all additional costs.

Solution.

Energy consumed/year	$= 80,000 \text{ kWh}$
Maximum kVA demand	$= 500$
Annual cost of supply	$= \text{M.D. Charges} + \text{Energy charges}$ $= \text{Rs } (120 \times 500 + 0.025 \times 80,000)$ $= \text{Rs } (60,000 + 2000) = \mathbf{\text{Rs } 62,000}$
$\cos \phi_1 = 0.707 \text{ lag}$; $\cos \phi_2 = 0.9 \text{ lag}$	
Max. kW demand at 0.707 p.f., P	$= 500 \times 0.707 = 353.3 \text{ kW}$
Leading kVAR taken by phase advancing equipment	$= P [\tan \phi_1 - \tan \phi_2]$ $= 353.3 [\tan (\cos^{-1} 0.707) - \tan (\cos^{-1} 0.9)]$ $= 353.3 [1 - 0.484] = 182.3 \text{ kVAR}$
Annual cost of phase advancing equipment	$= \text{Rs } 182.3 \times 50 \times 0.1 = \text{Rs } 912$

When p.f. is raised from 0.707 lag to 0.9 lag, new maximum kVA demand is = $353.3/0.9 = 392.6$ kVA.

$$\text{Reduction in kVA demand} = 500 - 392.6 = 107.4$$

$$\text{Annual saving in kVA charges} = \text{Rs } 120 \times 107.4 = \text{Rs } 12,888$$

As the units consumed remain the same, therefore, saving will be equal to saving in M.D. charges *minus* annual cost of phase advancing plant.

$$\therefore \text{Annual saving} = \text{Rs } (12,882 - 912) = \text{Rs } 11,976$$

TUTORIAL PROBLEMS

1. A factory which has a maximum demand of 175 kW at a power factor of 0.75 lagging is charged at Rs 72 per kVA per annum. If the phase advancing equipment costs Rs 120 per kVAR, find the most economical power factor at which the factory should operate. Interest and depreciation total 10% of the capital investment on the phase advancing equipment. **[0.986 leading]**
2. A consumer has a steady load of 500 kW at a power factor of 0.8 lagging. The tariff in force is Rs 60 per kVA of maximum demand plus 5 paise per kWh. If the power factor is improved to 0.95 lagging by installing phase advancing equipment, calculate :
 - (i) The capacity of the phase advancing equipment.
 - (ii) The annual saving effected.
 The phase advancing equipment costs Rs 100 per kVAR and the annual interest and depreciation together amount to 10%. **[(i) 210.6 kVAR (ii) Rs. 3,815]**
3. A factory has an average demand of 320 kW and an annual load factor of 50%. The power factor is 0.8 lagging. The tariff is Rs 80 per annum per kVA of maximum demand plus 5 paise per kWh. If the loss free capacitors costing Rs 100 per kVAR are to be utilised, find the value of power factor at which maximum saving will result. The interest and depreciation together amount to 12%. Also determine the annual saving effected by improving the power factor to this value. **[0.988 lagging ; Rs 3040]**
4. What will be the kVA rating of a phase advancing plant if it improves p.f. from 0.8 lagging to 0.891 lagging ? The consumer load is 1000 kW and the current taken by the phase advancer leads the supply voltage at a p.f. of 0.1. **[230 kVA]**
5. A consumer takes a steady load of 300 kW at a lagging power factor of 0.7 for 3000 hours a year. The tariff is Rs 130 per kVA of maximum demand annually and 4 paise per kWh. The annual cost of phase advancing plant is Rs 13 per kVAR. Determine the annual saving if the power factor of the load is improved ? **[Rs 12929.8]**

6.10 Meeting the Increased kW Demand on Power Stations

The useful output of a power station is the kW output delivered by it to the supply system. Sometimes, a power station is required to deliver more kW to meet the increase in power demand. This can be achieved by either of the following two methods :

- (i) By increasing the kVA capacity of the power station at the same power factor (say $\cos \phi_1$). Obviously, extra cost will be incurred to increase the kVA capacity of the station.
- (ii) By improving the power factor of the station from $\cos \phi_1$ to $\cos \phi_2$ without increasing the kVA capacity of the station. This will also involve extra cost on account of power factor correction equipment.

Economical comparison of two methods. It is clear that each method of increasing kW capacity of the station involves extra cost. It is, therefore, desirable to make economical comparison of the two methods. Suppose a power station of rating P kVA is supplying load at p.f. of $\cos \phi_1$. Let us suppose that the new power demand can be met either by increasing the p.f. to $\cos \phi_2$ at P kVA or by

TUTORIAL PROBLEMS

1. A system is working at its maximum capacity with a lagging power factor of 0.707. An anticipated increase in load can be met by (i) raising the power factor of the system to 0.87 lagging by the installation of phase advancers and (ii) by installing extra generating cables etc. to meet the increased power demand. The total cost of the latter method is Rs 110 per kVA. Estimate the limiting cost per kVA of the phase advancing plant which would justify the installation. **[Rs 76.26 per kVAR]**
2. For increasing the kW capacity of a power station working at 0.7 lagging power factor, the necessary increase in power can be obtained by raising power factor to 0.9 lagging or by installing additional plant. What is the maximum cost per kVA of power factor correction apparatus to make its use more economical than the additional plant at Rs 800 per kVA ? **[Rs 474 per kVA]**
3. An electrical system is working at its maximum kVA capacity with a lagging p.f. of 0.8. An anticipated increase of load can be met either by raising the p.f. of the system to 0.95 lagging by the installation of phase advancing plant or by erecting an extra generating plant and the required accessories. The total cost of the latter method is Rs 80 per kVA. Determine the economic limit cost per kVA of the phase advancing plant. Interest and depreciation may be assumed 12% in either case. **[Rs 37.50 per kVA]**

SELF-TEST

1. **Fill in the blanks by inserting appropriate words/figures.**
 - (i) The power factor of an a.c. circuit is given by power divided by power.
 - (ii) The lagging power factor is due to power drawn by the circuit.
 - (iii) Power factor can be improved by installing such a device in parallel with load which takes
 - (iv) The major reason for low lagging power factor of supply system is due to the use of motors.
 - (v) An over-excited synchronous motor on no load is known as
2. **Pick up the correct words/figures from the brackets and fill in the blanks.**
 - (i) The smaller the lagging reactive power drawn by a circuit, the is its power factor.
(smaller, greater)
 - (ii) The maximum value of power factor can be
(1, 0.5, 0.9)
 - (iii) KVAR = tan ϕ
(kW, KVA)
 - (iv) By improving the power factor of the system, the kilowatts delivered by the generating station are
(decreased, increased, not changed)
 - (v) The most economical power factor for a consumer is generally
(0.95 lagging, unity, 0.6 lagging)

ANSWER TO SELF-TEST

1. (i) active, apparent, (ii) lagging reactive (iii) leading reactive power, (iv) induction (v) synchronous condenser.
2. (i) greater, (ii) 1, (iii) kW, (iv) increased, (v) 0.95 lagging.

CHAPTER REVIEW TOPICS

1. Why is there phase difference between voltage and current in an a.c. circuit ? Explain the concept of power factor.
2. Discuss the disadvantages of a low power factor.
3. Explain the causes of low power factor of the supply system.
4. Discuss the various methods for power factor improvement.
5. Derive an expression for the most economical value of power factor which may be attained by a consumer.

6. Show that the economical limit to which the power factor of a load can be raised is independent of the original value of power factor when the tariff consists of a fixed charge per kVA of maximum demand plus a flat rate per kWh.
7. Write short notes on the following :
 - (i) Power factor improvement by synchronous condenser
 - (ii) Importance of p.f. improvement
 - (iii) Economics of p.f. improvement

DISCUSSION QUESTIONS

1. What is the importance of power factor in the supply system ?
2. Why is the power factor not more than unity ?
3. What is the effect of low power factor on the generating stations ?
4. Why is unity power factor not the most economical p.f. ?
5. Why a consumer having low power factor is charged at higher rates ?